

MOLINOS VERTICALES A 1.500 RPM.

SISTEMA DE ROTOR A DISCOS CON MARTILLOS OSCILANTES

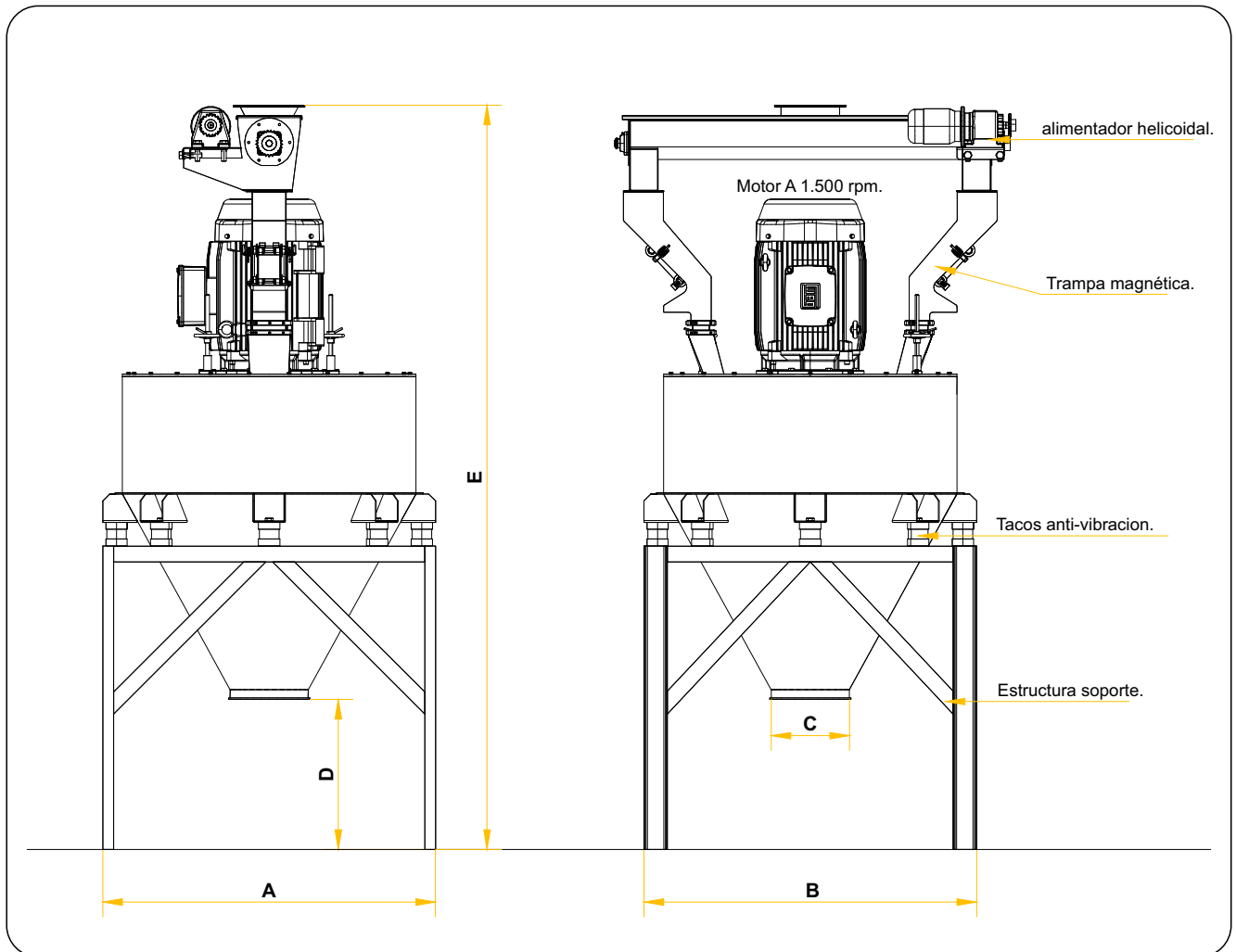

Modelo	Capacidad (kg/h)	Potencia (HP)	Dimensiones (mm)				
			A	B	C	D	E
PF 10.000 (1.500 RPM)	10.000	75 - 100	1.700	1.700	400	770	3.800